



---

## Fiber Optic Cabling Infrastructure Offering

**PANDUIT**<sup>®</sup>  
infrastructure for a connected world

## High-Speed Fiber Cabling Systems

Offers a high bandwidth and mission-critical physical infrastructures in data center, enterprise, industrial and campus networks with comprehensive fiber optic systems that deliver high performance, reliability, and scalability. The deployment of high-speed cabling systems has been increasing rapidly as data centers enable their physical infrastructure with 10 and 40 Gb/s capacity to support server virtualization, I/O consolidation, and convergence of backbone applications.

## Structured Cabling Infrastructure

A properly designed and implemented cabling infrastructure is a fundamental asset of every business. Carefully planning a structured cabling solution facilitates the delivery of new services, lowers network maintenance costs, and increases productivity. New high-bandwidth applications enable organizations to better fulfill their need for productivity and innovation in a rapidly changing world.

## Innovative Data Center Infrastructure Solutions

A comprehensive, intelligent data center offering that supports best practice methodologies. Our data center solutions enable physical to logical architecture integration, and deliver robust, scalable physical infrastructures that address:

- Visibility and control for managing and automating real-time data processes and documentation
- Convergence of new technologies and high-speed data applications
- Operational efficiency through process improvement and IT initiatives, such as cooling conservation through energy efficient data cabinets
- Capacity management for greater real estate utilization
- Modular pods designed to support high-density applications and provide consistent, reliable deployments while lowering infrastructure risk and costs

These fiber solutions facilitate faster implementation and simple specification, streamlining the process of designing, specifying, installing, and managing the increasingly complex physical infrastructure necessary to optimize your data center. Panduit knows the data center space intimately. We help you discover tangible infrastructure and business process improvements that increase functionality, interoperability, and manageability of mission-critical operations across your entire organization.

## PanNet™ System Warranty

All channels are field tested by Panduit Certified Installers (PCI) using industry standard hand-held devices which provide verified network performance, and ensures your network operates at optimal performance.

Cable Fire Ratings Reference Guide	4
<b><i>Premises Fiber Cables for the Americas</i></b>	
Plenum Rated Cable, Non-Conductive (OFNP)	4
Plenum Rated Cable, Conductive (OFCP)	4
Riser Rated Cable, Non-Conductive (OFNR)	4
Interconnect and PON Cable	5
Indoor Distribution Cable	5
Indoor Interlocking Armored Cable	6
Indoor-Outdoor Cable with Tight Buffered Fibers	6
Indoor-Outdoor Interlocking Armored Cable with Tight Buffered Fibers	7
Opticore Indoor-Outdoor All-Dielectric Cable	7
IndustrialNet Dielectric Double Jacketed DDJ Cable	8
Indoor-Outdoor Interlocking Armored Cable	8
All-Dielectric Outside Plant Cable	9
Armored Outside Plant Cable	9
Hybrid Powered Fiber Cable	10
<b><i>High Density Ribbon Fiber Cables for North America &amp; EMEA</i></b>	
12 to 144 Fiber Indoor Ribbon Fiber Cable	11
144 to 864 Fiber Indoor Ribbon Fiber Cable	11
<b><i>Premises Fiber Cables for EMEA</i></b>	
Interconnect Cable	12
Indoor Distribution Cable	12
Indoor-Outdoor Cable with Tight Buffered Fibres	13
Indoor-Outdoor Cable with Tight Buffered Fibres, 4km reels	13
Indoor-Outdoor All-Dielectric Cable, Gel-Filled	14
Indoor-Outdoor Armoured Cable, Gel-Filled	15
All-Dielectric Outside Plant Cable, Gel-Fille	16
Armoured Outside Plant Cable, Gel-Filled	16
<b><i>Premises Fiber Cables for APAC</i></b>	
Interconnect Cable	17
Indoor Distribution Cable	17
Indoor-Outdoor Cable with Tight Buffered Fibers	18
Indoor-Outdoor All-Dielectric Cable, Gel-Filled	18
All-Dielectric Outside Plant Cable, Gel-Filled	19
Armored Outside Plant Cable, Gel-Filled	19
<b><i>Fiber Cable Installation Accessories</i></b>	
Connectors and Toolkits	21

## **Cable Fire Ratings Reference Guide**

Cable fire ratings need to be considered when specifying cabling infrastructure to ensure local building codes are met. The below rating guide provides the information needed to determine which rating is appropriate for different installation environments.

### **Plenum Rated Cable, Non-Conductive (OFNP)**

A Plenum Rating (OFNP) signifies cable that has passed stringent burn testing and is suitable for installation into air plenum spaces. OFNP cables have fire-resistance and low smoke production characteristics. They are typically made with PVC sheathing and can be installed in ducts, plenums, and other spaces used for building airflow. This is the highest fire rating for North America fiber cable, and no other cable types can be used as substitutes.

### **Plenum Rated Cable, Conductive (OFCP)**

A Plenum Rating (OFCP) differs from OFNP in that the cable contains metallic elements, typically armor, and therefore, conducts electricity. All other aspects of this rating are the same as OFNP.

### **Riser Rated Cable, Non-Conductive (OFNR)**

A Riser Rating (OFNR) is commonly required when cables are run between floors through open vertical shafts. OFNR cables are used in Riser areas which are building vertical shafts or runs from one floor to another floor. OFNR cables cannot be installed in plenum areas since they do not have the required smoke rating as plenum rated cables. OFNP plenum cables can be used as substitutes for OFNR Riser cables.

### **Riser Rated Cable, Conductive (OFCR)**

A Riser Rating (OFCR) differs from OFNR in that the cable contains metallic elements, such as a layer of armor, and therefore, conducts electricity. All other aspects of this rating are the same as OFNR.

### **Low Smoke Zero Halogen (LSZH)**

A Low Smoke Zero Halogen Rating (LSZH) is sometimes referred to as low toxicity cable. When burned, PVC-based cables produce a cloud of toxic smoke containing corrosive compounds. LSZH cables do not contain the halogen type compounds that form these toxic substances. LSZH ratings are expressed as OFN-LS or OFNR-LS if the cable also meets the requirements of OFNR rated cable.

### **EuroClass and UKCA**

EuroClass cable for the EMEA market is LSZH cable that has been tested to more stringent standards and labeling requirements as per the EU's Construction Products Regulation. EuroClass ratings range from B2ca, the highest applicable rating for communications cable, to Fca, which is non-rated or self-declared. Each level of EuroClass cable from B2ca down to Dca are further characterized by Smoke, Flaming Droplets, and Acidity ratings. Local regulations vary on which rating can be used in which application, so it is important to understand the local requirement. Further information on Panduit's EuroClass offering is available at the [CPR landing page](#). Many of Panduit's EuroClass cables also comply with UKCA.

### **Non-Flame Rated**

Outside Plant (OSP) cables are intended for outdoor use only. Typically, these cables are constructed using varying densities of Polyethylene (PE) in the outer jacket. Because cables without flame ratings do not contain flame suppressants and emit noxious gasses when burned, building codes often restrict the distance installers are permitted to route inside buildings before termination to 50 feet or 15 meters.

## Opticore® Interconnect and PON Cable

- Indoor cable used in interconnect, horizontal installations, patch cords and routing in tight spaces
- Can be installed in cable trays and panels; supports applications including FTTH
- Bend-insensitive singlemode (ITU G.657.A1) with 1 and 2 fiber round cable for Passive Optical Networking (PON)

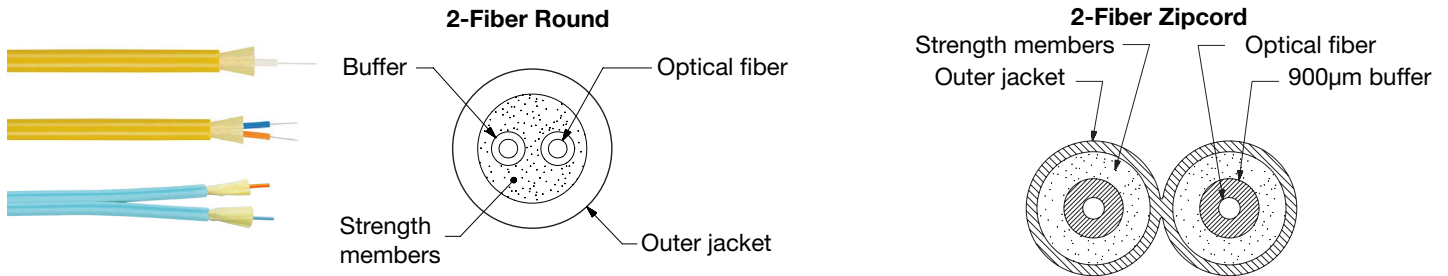

	1-Fiber, Riser	2-Fiber Round, Riser	2-Fiber Zipcord, Riser	2-Fiber Zipcord, Plenum
<b>Multimode OM3</b>	-	-	FOIRX02Y	FOIPX02Y
<b>Multimode OM4</b>	-	-	FOIRZ02Y	FOIPZ02Y
<b>Singlemode G.652.D</b>	-	-	FSIR902Y	FSIP902Y
<b>Singlemode G.657.A1</b>	FSIRA01Y	FSDRA02Y	-	-

## Opticore® Indoor Distribution Cable

- For indoor use in intra-building backbone and horizontal installations
- Optical fiber is clad in 900µm buffer coating for easy connectorization



	Flame rating	6-Fiber	12-Fiber	24-Fiber	48-Fiber	72-Fiber	96-Fiber	144-Fiber
<b>Multimode OM3</b>	LSZH	FODLX06	FODLX12	FODLX24	-	-	-	-
	Plenum	FODPX06Y	FODPX12Y	FODPX24Y	FODPX48Y	-	-	-
	Riser	FODRX06Y	FODRX12Y	FODRX24Y	FODRX48Y	-	FODRX96Y	-
<b>Multimode OM4</b>	LSZH	FODLZ06	FODLZ12	FODLZ24	-	-	-	-
	Plenum	FODPZ06Y	FODPZ12Y	FODPZ24Y	FODPZ48Y	-	-	-
	Riser	FODRZ06Y	FODRZ12Y	FODRZ24Y	FODRZ48Y	-	-	-
<b>Multimode OM5</b>	Plenum	FODPW06Y	FODPW12Y	FODPW24Y	-	-	-	-
<b>Singlemode</b>	LSZH	FSDL906	FSDL912	FSDL924	-	-	-	-
	Plenum	FSDP906Y	FSDP912Y	FSDP924Y	FSDP948Y	FSDP972Y	FSDP996Y	FSDP91AY
	Riser	FSDR906Y	FSDR912Y	FSDR924Y	FSDR948Y	FSDR972Y	FSDR996Y	FSDR91AY

# Premises Fiber Cables for the Americas (North America and Latin America)

## Opticore Indoor Interlocking Armored Cable

- Indoor applications include intra-building backbones and horizontal installations
- Interlocking aluminum armor eliminates the need for inner duct and provides a small crush resistant pathway
- Optical fiber is clad in 900µm buffer coating for easy connectorization

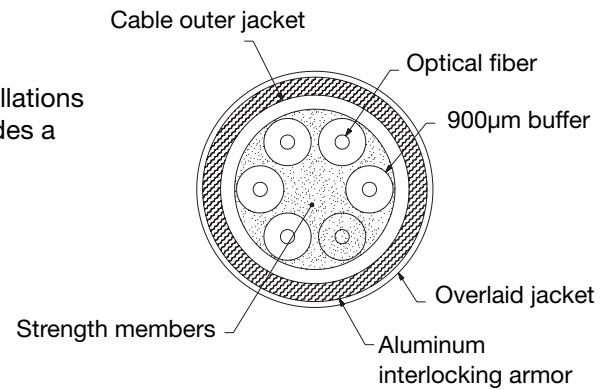

	Flame rating	6-Fiber	12-Fiber	24-Fiber	48-Fiber	72-Fiber	96-Fiber	144-Fiber
<b>Multimode OM3</b>	Plenum	FOPPX06Y	FOPPX12Y	FOPPX24Y	FOPPX48Y	-	-	-
	Riser	FOPRX06Y	FOPRX12Y	FOPRX24Y	FOPRX48Y	-	-	-
	Plenum	FOPPZ06Y	FOPPZ12Y	FOPPZ24Y	FOPPZ48Y	-	-	-
<b>Multimode OM4</b>	Riser	FOPRZ06Y	FOPRZ12Y	FOPRZ24Y	FOPRZ48Y	-	-	-
	Plenum	FOPPW06Y	FOPPW12Y	FOPPW24Y	-	-	-	-
<b>Multimode OM5</b>	Plenum	FSPP906Y	FSPP912Y	FSPP924Y	FSPP948Y	FSPP972Y	FSPP996Y	FSPP91AY
<b>Singlemode</b>	Riser	FSPR906Y	FSPR912Y	FSPR924Y	FSPR948Y	-	-	-

## Opticore Indoor-Outdoor Cable with Tight Buffered Fibers

- Indoor-Outdoor 900µm tight-buffered cable provides UV resistance, dry water blocking, high density and easy installation
- All-dielectric cable provides an effective solution for inter-building, ducts and entrance facilities

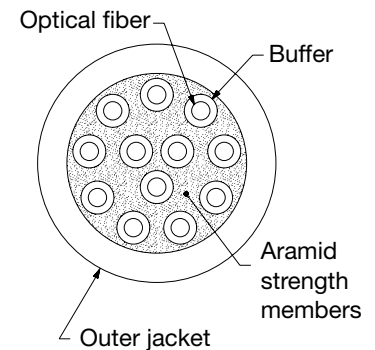

	Flame rating	6-Fiber	12-Fiber	24-Fiber	48-Fiber	72-Fiber	96-Fiber	144-Fiber
<b>Multimode OM1</b>	Plenum	FSKP606	FSKP612	-	-	-	-	-
	Riser	FSKR606	FSKR612	-	-	-	-	-
<b>Multimode OM3</b>	Plenum	FOKPX06	FOKPX12	FOKRX24	FOKPX48	-	-	-
	Riser	FOKRX06	FOKRX12	FOKRZ24	FOKRX48	-	-	-
<b>Multimode OM4</b>	Plenum	FOKPZ06	FOKPZ12	FOKPZ24	FOKPZ48	-	-	-
	Riser	FOKRZ06	FOKRZ12	FOKRZ24	FOKRZ48	-	-	-
<b>Singlemode</b>	Plenum	FSKP906	FSKP912	FSKR924	FSKP948	FSKP972	FSKP996	-
	Riser	FSKR906	FSKR912	FSKR924	FSKR948	FSKR972	FSKR996	FSKR91A

**Opticore Indoor-Outdoor Interlocking Armored Cable with Tight Buffered Fibers**

- Interlocking aluminum armor eliminates the need for inner duct or conduit and provides a smaller crush resistant pathway
- Fibers are clad with 900µm tight buffered fibers for easy connectorization
- UV-resistant outer jacket and dry water-blocking technology support

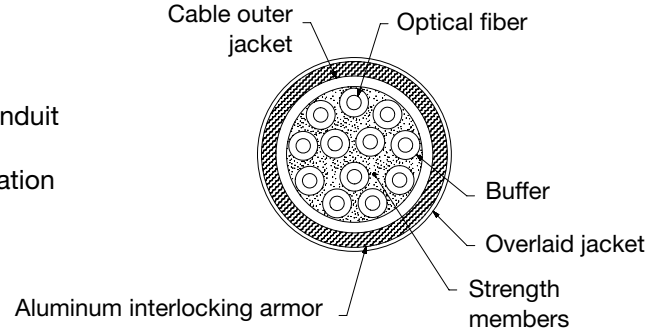

	Flame rating	6-Fiber	12-Fiber	24-Fiber	48-Fiber	72-Fiber	96-Fiber	144-Fiber
<b>Multimode OM1</b>	Plenum	FSLP606	FSLP612	-	-	-	-	-
	Riser	FSLR606	FSLR612	-	-	-	-	-
	Plenum	FOLPX06	FOLPX12	FOLPX24	-	-	-	-
<b>Multimode OM3</b>	Riser	FOLRX06	FOLRX12	FOLRX24	-	-	-	-
	Plenum	FOLPZ06	FOLPZ12	FOLPZ24	-	-	-	-
<b>Multimode OM4</b>	Riser	FOLRZ06	FOLRZ12	FOLRZ24	-	-	-	-
<b>Singlemode</b>	Plenum	FSLP906	FSLP912	FSLP924	FSLP948	FSLP972	FSLP996	-
	Riser	FSLR906	FSLR912	FSLR924	FSLR948	FSLR972	FSLR996	FSLR91A

**Opticore Indoor-Outdoor All-Dielectric Cable**

- Flame rated cable offers UV resistance, dry water-blocking, high density and easy installation
- All-dielectric, gel-free cable provides an effective solution for inter-building, ducts and entrance facilities
- Options include central loose tube and stranded loose tube

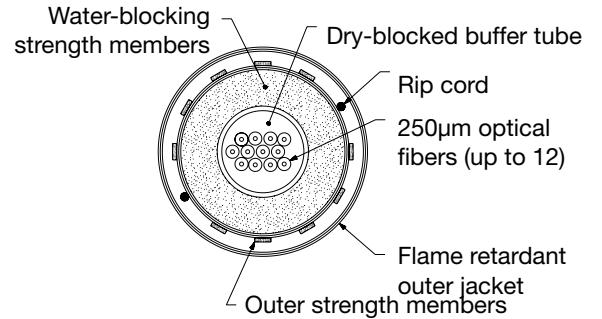

	Flame rating	Central tube			Stranded Tube			
		6-Fiber	12-Fiber	24-Fiber	48-Fiber	72-Fiber	96-Fiber	144-Fiber
<b>Multimode OM1</b>	Plenum	FSCP606Y	FSCP612Y	-	-	-	-	-
	Riser	FSCR606Y	FSCR612Y	-	-	-	-	-
<b>Multimode OM3</b>	LSZH	FOCLX06	FOCLX12	FONLX24Y	FONLX48Y	-	-	-
	Plenum	FOCPX06Y	FOCPX12Y	FONPX24Y	FONPX48Y	-	-	-
	Riser	FOCRX06Y	FOCRX12Y	FONRX24Y	FONRX48Y	-	FONRX96Y	FONRX1AY
<b>Multimode OM4</b>	LSZH	FOCLZ06	FOCLZ12	FONLZ24Y	FONLZ48Y	-	-	-
	Plenum	FOCPZ06Y	FOCPZ12Y	FONPZ24Y	FONPZ48Y	-	-	-
	Riser	FOCRZ06Y	FOCRZ12Y	FONRZ24Y	FONRZ48Y	-	-	-
<b>Singlemode</b>	LSZH	FSCL906	FSCL912	FSNL924Y	FSNL948Y	-	-	-
	Plenum	FSCP906Y	FSCP912Y	FSNP924Y	FSNP948Y	FSNP972Y	FSNP996Y	FSNP91AY
	Riser	FSCR906Y	FSCR912Y	FSNR924Y	FSNR948Y	FSNR972Y	FSNR996Y	FSNR91AY

# Premises Fiber Cables for the Americas

(North America and Latin America)

## IndustrialNet™ Dielectric Double Jacketed DDJ Cable

- Rugged metal-free construction is crush resistant and does not require grounding & bonding
- Dry water blocked and dual flame rated as Riser (OFNR) and Low Smoke Zero Halogen (LSZH)
- Can be installed indoors using J-Hooks or outdoors as direct bury, aerial with lashing to messenger wire

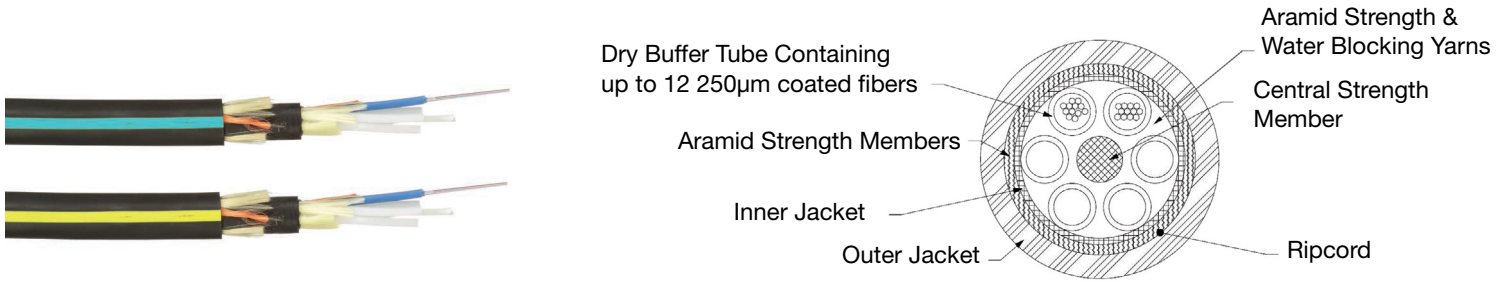

	Flame rating	6-Fiber	12-Fiber	24-Fiber	48-Fiber	96-Fiber
<b>Multimode OM4</b>	LSZH-Riser	FOJDZ06	FOJDZ12	FOJDZ24	–	–
<b>Singlemode</b>	LSZH-Riser	FSJD906	FSJD912	FSJD924	FSJD948	FSJD996

## Opticore Indoor-Outdoor Interlocking Armored Cable

- Interlocking aluminum armor eliminates the need for inner duct or conduit and provides a smaller crush resistant pathway
- UV resistant, dry water-blocked loose tube construction is gel-free and can be used for aerial applications (using messenger wire) and direct burial



	Flame rating	6-Fiber	12-Fiber	24-Fiber	48-Fiber	72-Fiber	96-Fiber	144-Fiber
<b>Multimode OM1</b>	Plenum	FSGP606Y	FSGP612Y	FSMP624Y	–	–	–	–
	Riser	FSGR606Y	FSGR612Y	FSMR624Y	–	–	–	–
<b>Multimode OM3</b>	Plenum	FOGPX06Y	FOGPX12Y	FOMPX24Y	–	–	–	–
	Riser	FOGRX06Y	FOGRX12Y	FOMRX24Y	–	–	–	–
<b>Multimode OM4</b>	Plenum	FOGPZ06Y	FOGPZ12Y	FOMPZ24Y	–	–	–	–
	Riser	FOGRZ06Y	FOGRZ12Y	FOMRZ24Y	–	–	–	–
<b>Singlemode</b>	Plenum	FSGP906Y	FSGP912Y	FSMP924Y	FSMP948Y	FSMP972Y	FSMP996Y	FSMP91AY
	Riser	FSGR906Y	FSGR912Y	FSMR924Y	FSMR948Y	–	–	–



## Opticore All-Dielectric Outside Plant Cable

- Gel-free with dry water blocking elements and UV resistant outer jacket
- For use in aerial (with messenger wire) and duct applications
- Non-metallic cable does not require grounding and bonding

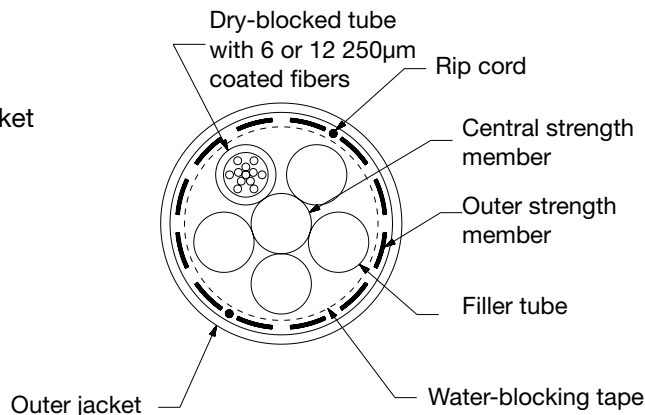
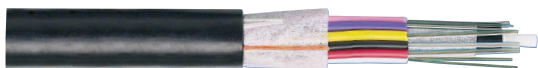

	6-Fiber	12-Fiber	24-Fiber	48-Fiber	72-Fiber	96-Fiber	144-Fiber
<b>Multimode OM3</b>	FOTNX06	FOTNX12	FOTNX24	-	-	-	-
<b>Multimode OM4</b>	FOTNZ06	FOTNZ12	FOTNZ24	-	-	-	-
<b>Singlemode</b>	FSTN906	FSTN912	FSTN924	FSTN948	FSTN972	FSTN996	FSTN91A

## Opticore Armored Outside Plant Cable

- Corrugated steel tape armor provides crush resistance and rodent protection
- Gel-free with dry water blocking elements and UV resistant outer jacket
- Applications include ducts, trays and direct burial

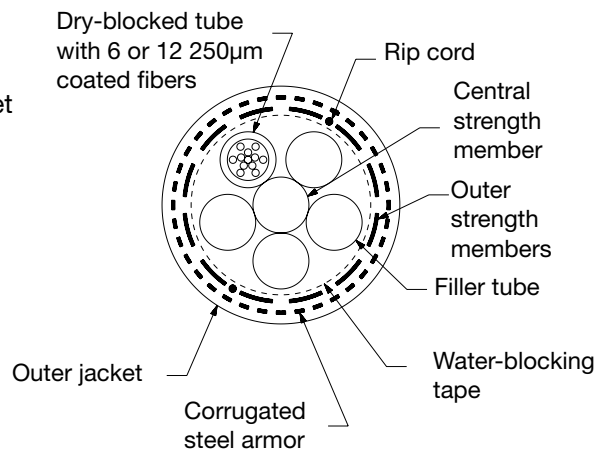

	6-Fiber	12-Fiber	24-Fiber	48-Fiber	72-Fiber	96-Fiber	144-Fiber
<b>Multimode OM1</b>	FSWN606	FSWN612	-	-	-	-	-
<b>Multimode OM3</b>	FOWNX06	FOWNX12	FOWNX24	-	-	-	-
<b>Multimode OM4</b>	FOWNZ06	FOWNZ12	FOWNZ24	-	-	-	-
<b>Singlemode</b>	FSWN906	FSWN912	FSWN924	FSWN948	FSWN972	FSWN996	FSWN91A

# Premises Fiber Cables for the Americas

(North America and Latin America)

## Opticore Hybrid Powered Fiber Cable

- Hybrid cable contains Singlemode (Bend-Insensitive) optical fibers and 12 AWG copper conductors for use in delivering data signals and power to remote devices (wireless access points and surveillance cameras)
- Rugged water blocked cable suitable for indoor and outdoor use
- Options include 2 Fibers (simplex breakout) with 2 conductors or 12 Fibers (loose tube) with 4 or 6 conductors
- Riser rated

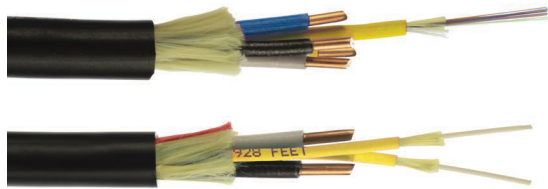

**Breakout style**

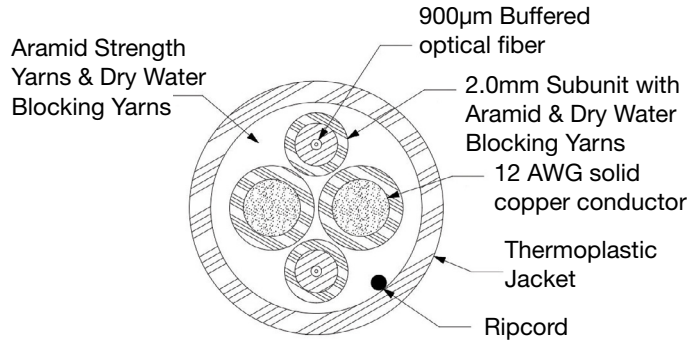

**Loose tube style**

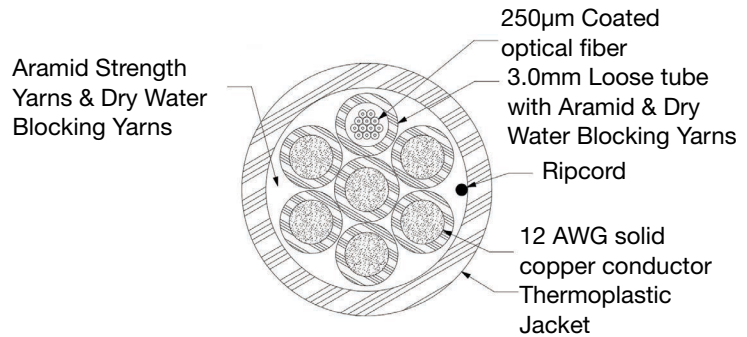

	2-Fiber Breakout 2 Conductor	12-Fiber Loose Tube 4 Conductor	12-Fiber Loose Tube 6 Conductor
Singlemode G.657.A2/B2	FSHRB02-02S12A	FSHRB12-04S12C	FSHRB12-06S12C

## Opticore 12 to 144 Fiber Indoor Ribbon Fiber Cable

- For indoor data center pathways
- Terminate 12 fibers at a time with flat or flexible ribbons, compatible with Panduit MPO pigtails and connectors

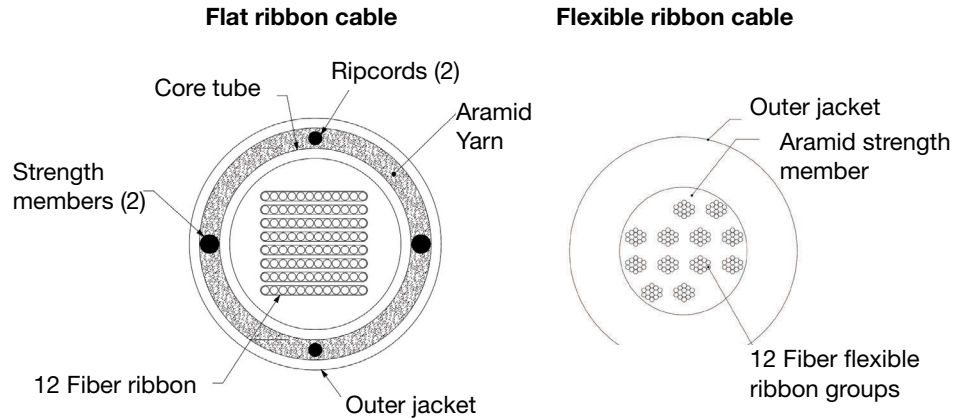
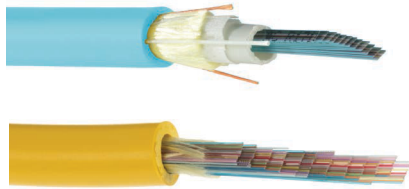

	6-Fiber	12-Fiber	24-Fiber	48-Fiber	72-Fiber	96-Fiber	144-Fiber
<b>Multimode OM4</b>	Plenum	FFDPZF012F	FFDPZF024F	FFDPZF048F	FFDPZF072F	FFDPZF096F	–
<b>Singlemode G.657.A1</b>	Plenum	–	–	–	–	–	FFDPAX144F
<b>Singlemode G.657.A2/B2</b>	Plenum	FFDPBF012F	FFDPBF024F	FFDPBF048F	FFDPBF072F	FFDPBF096F	–
	Riser-LSZH-B2ca	–	–	–	–	–	FFDDBF144-18M

6th character of part number is ribbon type: F = Flat ribbon, X = Flexible ribbon  
Last character of part number is unit of measure: M = Meters, F = Feet

## Opticore 144 to 864 Fiber Indoor Ribbon Fiber Cable

- For building-to-building and within data center halls; install on ladder rack or in ducts
- Flexible 12-fiber ribbons enable small cable diameter and are compatible with Panduit MPO pigtails and connectors

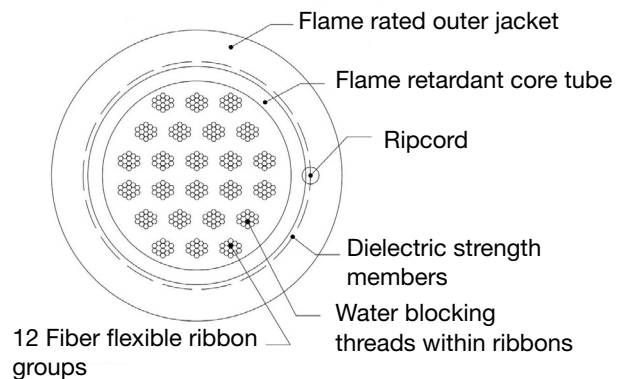

	Flame rating	144-Fiber	288-Fiber	432-Fiber	576-Fiber	864-Fiber
<b>Singlemode G.657.A2/B2</b>	Riser-LSZH-Cca	FFCDBX144-28M	FFCDBX288-28M	FFCDBX432-28M	FFCDBX576-29M	FFCDBX864-29M
	LSZH-Cca	–	FFCOBX288-24F	–	–	–
	LSZH-B2ca	FFDCBT144-14M	FFDCBT288-14M			

6th character of part number is ribbon type: F = Flat ribbon, X = Flexible ribbon  
Last character of part number is unit of measure: M = Meters, F = Feet

# Premises Fibre Cables for EMEA

(Europe, Middle East, and Africa)

## Opticore Interconnect Cable

- Indoor cable used in interconnect, horizontal installations, patch cords and routing in tight spaces
- Can be installed in cable trays and panels; supports applications including FTTH

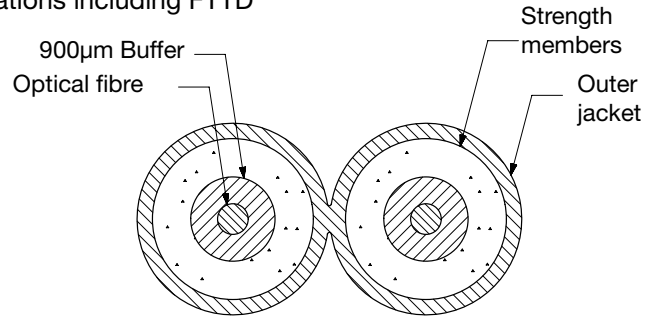

	EuroClass	2-Fibre Zipcord
<b>Multimode OM3</b>	Eca	FAICX02-40
<b>Multimode OM4</b>	Eca	FAICZ02-40
<b>Singlemode G.657.A1</b>	Eca	FAIC902-40

## Opticore Indoor Distribution Cable

- For indoor use in intra-building backbone and horizontal installations
- Optical fibre is clad in 900µm buffer coating for easy connectorization

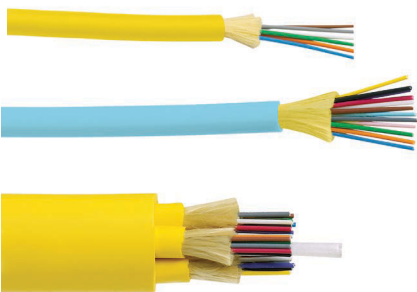

	EuroClass	4-Fibre	6-Fibre	8-Fibre	12-Fibre	24-Fibre	48-Fibre	72-Fibre	96-Fibre
<b>Multimode OM3</b>	Cca	-	-	-	FADCX12-24	FADCX24-24	-	-	-
	Dca	FADCX04-37	FADCX06-37	FADCX08-37	FADCX12-37	FADCX24-37	-	-	-
<b>Multimode OM4</b>	Cca	FADCZ04-24	FADCZ06-24	FADCZ08-24	FADCZ12-24	FADCZ24-24	-	-	-
	Dca	FADCZ04-37	FADCZ06-37	FADCZ08-37	FADCZ12-37	FADCZ24-37	-	-	-
	Eca	-	-	-	-	-	FAECZ48-40	FAECZ72-40	FAECZ96-40
<b>Singlemode G.657.A1</b>	Cca	FADC904-24	FADC906-24	FADC908-24	FADC912-24	FADC924-24	-	-	-
	Dca	FADC904-37	FADC906-37	FADC908-37	FADC912-37	FADC924-37	-	-	-
	Eca	-	-	-	-	-	FAEC948-40	FAEC972-40	FAEC996-40

### Opticore Indoor-Outdoor Cable with Tight Buffered Fibres

- 900µm tight buffered cable provides UV and moisture resistance
- Cca version includes dry water blocking elements (longitudinally water blocked)
- For high density and easy installation
- All-dielectric cable provides an effective solution for inter-building, ducts and entrance facilities

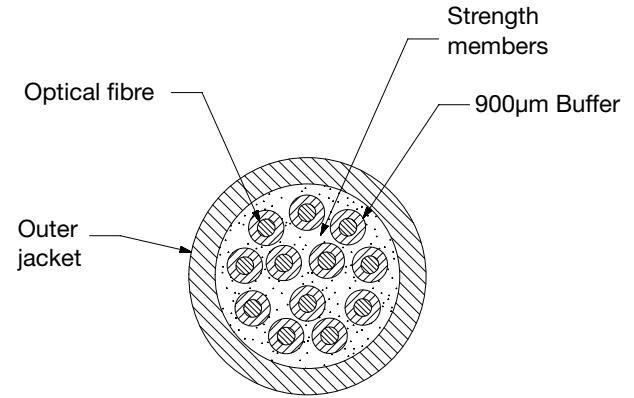

	EuroClass	2-Fibre	4-Fibre	12-Fibre	24-Fibre
<b>Multimode OM3</b>	Cca	-	-	FAKCX12-24	FAKCX24-24
	Eca	-	-	FAKCX12-40	FAKCX24-40
<b>Multimode OM4</b>	Cca	-	-	FAKCZ12-24	FAKCZ24-24
	Eca	-	FAKCZ04-40	FAKCZ12-40	FAKCZ24-40
<b>Multimode OM5</b>	Cca	-	-	FAKCW12-24	FAKCW24-24
<b>Singlemode G.657.A1</b>	Cca	FAKC902-24	-	FAKC912-24	FAKC924-24
	Eca	FAKC902-40	-	FAKC912-40	FAKC924-40

### Opticore Indoor-Outdoor Cable with Tight Buffered Fibres, 4km reels

- Packaged as single reel with 4 kilometers; ideal for distributors to stock along with Panduit fibre optic connectivity solutions
- UV and moisture resistant with outer jacket that is aqua for multimode, yellow for singlemode

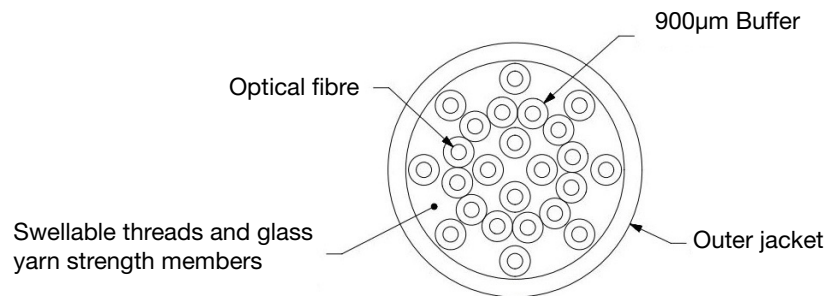
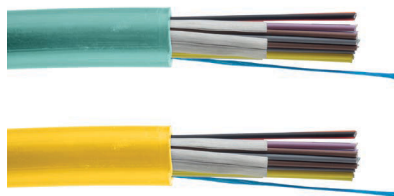

	EuroClass	12-Fibre	24-Fibre
<b>Multimode OM4</b>	Cca	FAACZ12-24-4K	FAACZ24-24-4K
<b>Singlemode G.657.A1</b>	Cca	FAAC912-24-4K	FAAC924-24-4K

**Opticore Indoor-Outdoor All-Dielectric Cable, Gel-Filled**

- Flame rated cable offers UV resistance, water blocking, high density and easy installation
- All-dielectric cable provides an effective solution for inter-building, ducts and entrance facilities
- Options include central loose tube and stranded loose tube (both are gel-filled)

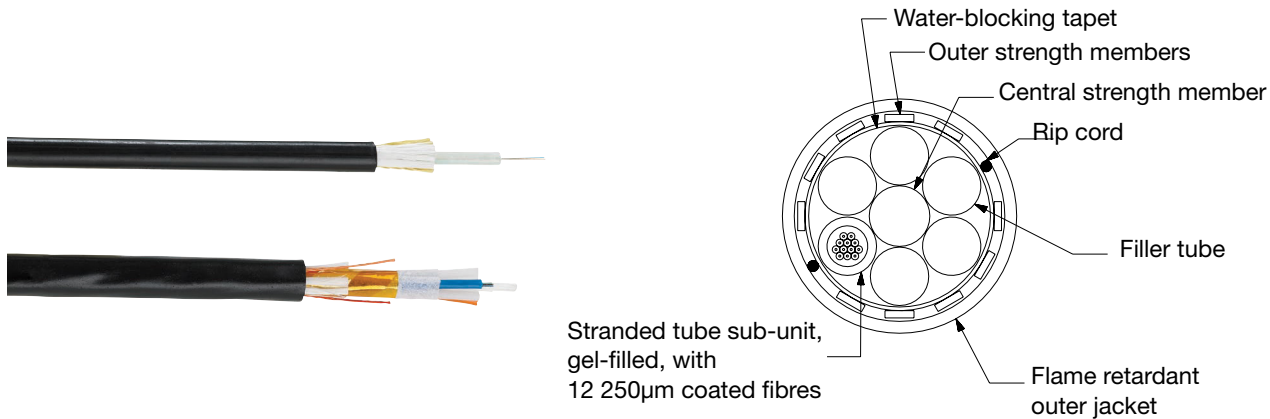

**Central Tube**

	<b>EuroClass</b>	<b>4-Fibre</b>	<b>6-Fibre</b>	<b>8-Fibre</b>	<b>12-Fibre</b>	<b>24-Fibre</b>
<b>Multimode OM3</b>	Cca	–	–	–	FACCX12-24	FACCX24-24
	Eca	FACCX04-40	FACCX06-40	FACCX08-40	FACCX12-40	FACCX24-40
<b>Multimode OM4</b>	B2ca	–	–	–	FACCZ12-14	FACCZ24-14
	Cca	FACCZ04-24	FACCZ06-24	FACCZ08-24	FACCZ12-24	FACCZ24-24
	Eca	FACCZ04-40	FACCZ06-40	FACCZ08-40	FACCZ12-40	FACCZ24-40
<b>Multimode OM5</b>	Cca	–	–	–	FACCW12-24	FACCW24-24
<b>Singlemode</b>	B2ca	–	–	–	FACC912-14	FACC924-14
	Cca	FACC904-24	FACC906-24	FACC908-24	FACC912-24	FACC924-24
	Eca	FACC904-40	FACC906-40	FACC908-40	FACC912-40	FACC924-40

**Stranded Tube**

	<b>EuroClass</b>	<b>48-Fibre</b>	<b>72-Fibre</b>	<b>96-Fibre</b>	<b>144-Fibre</b>
<b>Multimode OM4</b>	Cca	FANCZ48-24	–	–	–
	Eca	FANCZ48-40	–	–	–
<b>Singlemode G.657.A1</b>	Cca	FANC948-24	FANC972-24	FANC996-24	FANC91A-24
	Eca	FANC948-40	FANC972-40	FANC996-40	FANC91A-24

**Opticore Indoor-Outdoor Armoured Cable, Gel-Filled**

- Flame rated cable offers UV resistance, water blocking, high density and easy installation
- Corrugated steel tape armour is suitable for ducts, trays and direct burial
- Options include central loose tube and stranded loose tube (both are gel-filled)

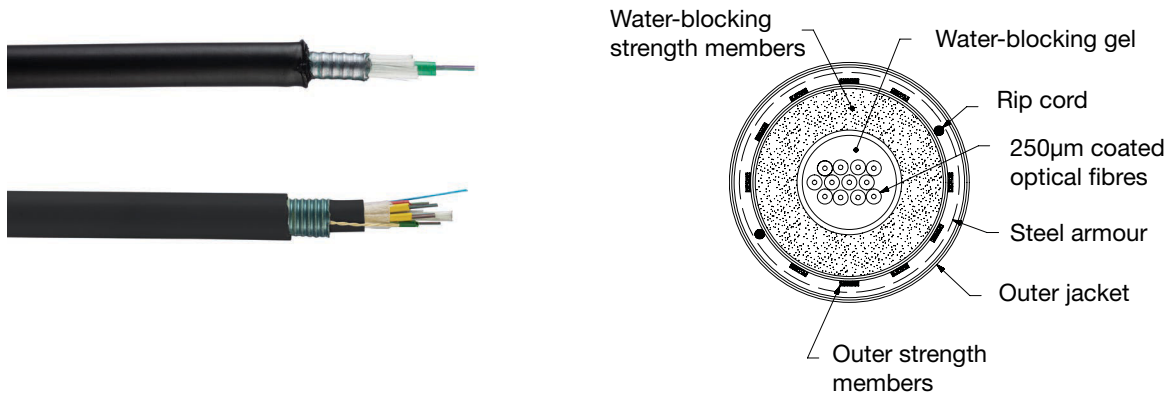

	EuroClass	Central Tube		Stranded Tube			
		12-Fibre	24-Fibre	48-Fibre	72-Fibre	96-Fibre	144-Fibre
<b>Multimode OM3</b>	Eca	FAGCX12-40	FAGCX24-40	–	–	–	–
<b>Multimode OM4</b>	B2ca	FAGCZ12-14	FAGCZ24-14	FAMCZ48-14	FAMCZ72-14	FAMCZ96-14	FAMCZ1A-14
	Cca	–	–	FAMCZ48-24	FAMCZ72-24	FAMCZ96-24	FAMCZ1A-24
	Eca	FAGCZ12-40	FAGCZ24-40	–	–	–	–
<b>Singlemode G.657.A1</b>	B2ca	FAGC912-14	FAGC924-14	FAMC948-14	FAMC972-14	FAMC996-14	FAMC91A-14
	Cca	–	–	FAMC948-24	FAMC972-24	FAMC996-24	FAMC91A-24
	Eca	FAGC912-40	FAGC924-40	FAMC948-40	–	–	–

# Premises Fibre Cables for EMEA (Europe, Middle East, and Africa)

## Opticore All-Dielectric Outside Plant Cable, Gel-Fille

- Gel-filled water blocked loose tubes and UV resistant outer jacket
- For use in aerial (with messenger wire) and duct applications
- Non-metallic cable does not require grounding and bonding

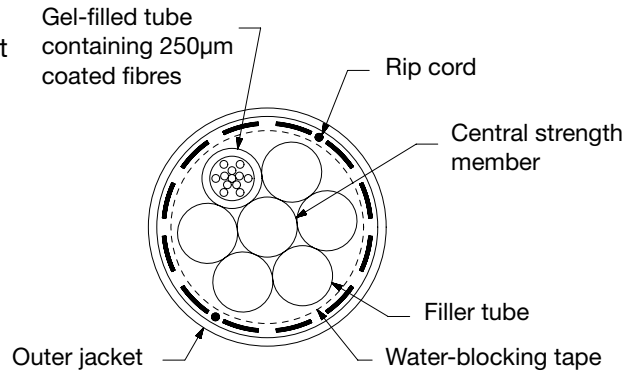
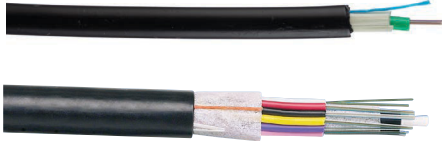

	Central Tube		Stranded Tube			
	4-Fibre	6-Fibre	48-Fibre	72-Fibre	96-Fibre	144-Fibre
<b>Multimode OM4</b>	FQUNZ04	FQUNZ06	-	-	-	-
<b>Singlemode G.657.A1</b>	FPUN904	FPUN906	FPTN948	FPTN972	FPTN996	FPTN91A

## Opticore Armoured Outside Plant Cable, Gel-Filled

- Corrugated steel tape armour provides crush resistance and rodent protection
- Gel-filled water blocked loose tubes and UV resistant outer jacket
- Applications include ducts, trays and direct burial

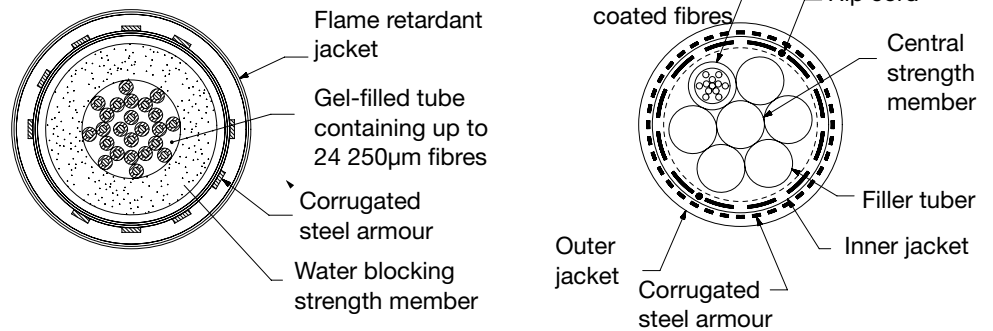

### Central Tube, Single Armour Single Jacket

	4-Fibre	6-Fibre	8-Fibre	12-Fibre	24-Fibre
<b>Multimode OM4</b>	-	FQSNZ06	-	FQSNZ12	FQSNZ24
<b>Singlemode G.657.A1</b>	FPSN904	FPSN906	FPSN908	FPSN912	FPSN924

### Stranded Tube, Single Armour Double Jacket

	8-Fibre	12-Fibre	24-Fibre	48-Fibre	72-Fibre	96-Fibre	144-Fibre
<b>Singlemode G.657.A1</b>	FPQN908B	FPQN912B	FPQN924B	FPQN948B	FPQN972B	FPQN996B	FPQN91AB



## Opticore Interconnect Cable

- Indoor cable used in interconnect, horizontal installations, patch cords and routing in tight spaces
- Can be installed in cable trays and panels; supports applications including FTTH



	2-Fiber Zipcord, Riser	2-Fiber Zipcord, LSZH
<b>Multimode OM3</b>	FLIRX02Y	FLILX02Y
<b>Multimode OM4</b>	FLIRZ02Y	FLILZ02Y
<b>Singlemode</b>	FLIR902Y	FLIL902Y

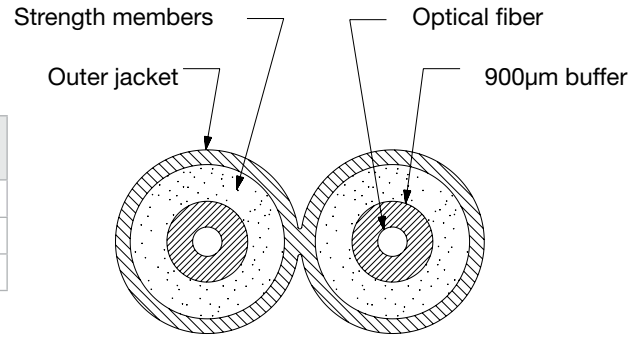

## Opticore® Indoor Distribution Cable

- For indoor use in intra-building backbone and horizontal installations
- Optical fiber is clad in 900µm buffer coating for easy connectorization



	Flame rating	2-Fiber	4-Fiber	6-Fiber	8-Fiber	12-Fiber	24-Fibre	48-Fiber
<b>Multimode OM3</b>	LSZH	FLDLX02Y	FLDLX04Y	FLDLX06Y	FLDLX08Y	FLDLX12Y	FLDLX24Y	FLDLX48Y
	Riser	FLDRX02Y	FLDRX04Y	FLDRX06Y	FLDRX08Y	FLDRX12Y	FLDRX24Y	FLDRX48Y
<b>Multimode OM4</b>	LSZH	FLDLZ02Y	FLDLZ04Y	FLDLZ06Y	FLDLZ08Y	FLDLZ12Y	FLDLZ24Y	FLDLZ48Y
	Riser	FLDRZ02Y	FLDRZ04Y	FLDRZ06Y	FLDRZ08Y	FLDRZ12Y	FLDRZ24Y	FLDRZ48Y
<b>Singlemode G.657.A1</b>	LSZH	FLDL902Y	FLDL904Y	FLDL906Y	FLDL908Y	FLDL912Y	FLDL924Y	FLDL948Y
	Riser	FLDR902Y	FLDR904Y	FLDR906Y	FLDR908Y	FLDR912Y	FLDR924Y	FLDR948Y

## Opticore Indoor-Outdoor Cable with Tight Buffered Fibers

- Indoor-Outdoor 900µm tight-buffered cable provides UV resistance, dry water blocking, high density and easy installation
- All-dielectric cable provides an effective solution for inter-building, ducts and entrance facilities

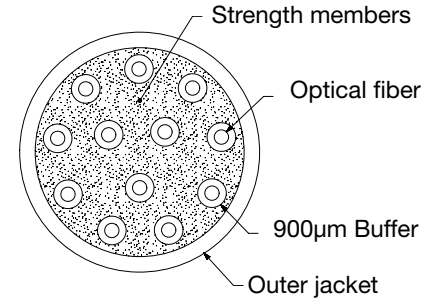

	Flame rating	4-Fiber	6-Fiber	8-Fiber	12-Fiber	24-Fiber	48-Fiber	72-Fiber
<b>Multimode OM3</b>	LSZH	FLKLX04	FLKLX06	FLKLX08	FLKLX12	FLKLX24	-	-
	Riser	FLKRX04	FLKRX06	FLKRX08	FLKRX12	FLKRX24	-	-
<b>Multimode OM4</b>	LSZH	FLKLZ04	FLKLZ06	FLKLZ08	FLKLZ12	FLKLZ24	-	-
	Riser	FLKRZ04	FLKRZ06	FLKRZ08	FLKRZ12	FLKRZ24	-	-
<b>Singlemode</b>	LSZH	FLKL904	FLKL906	FLKL908	FLKL912	FLKL924	FLKL948	FLKL972
	Riser	FLKR904	FLKR906	FLKR908	FLKR912	FLKR924	FLKR948	FLKR972

## Opticore Indoor-Outdoor All-Dielectric Cable, Gel-Filled

- Flame rated cable offers UV resistance, water blocking, high density and easy installation
- All-dielectric cable provides an effective solution for inter-building, ducts and entrance facilities
- Options include central loose tube and stranded loose tube (both are gel-filled)

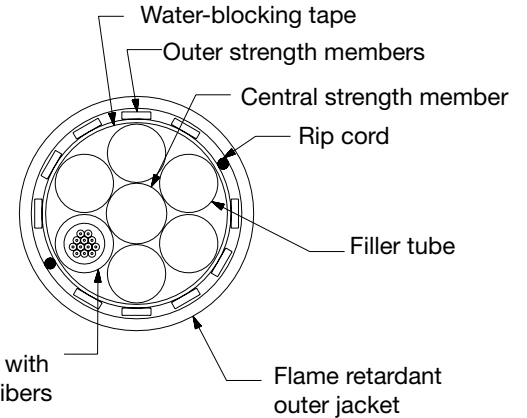

Stranded tube sub-unit, gel-filled, with 12 250µm coated fibers

	Flame rating	Central Tube			Stranded Tube	
		4-Fiber	6-Fiber	12-Fiber	24-Fiber	48-Fiber
<b>Multimode OM3</b>	LSZH	FLCLZ04Y	FLCLZ06Y	FLCLZ12Y	FLNLZ24Y	FLNLZ48Y
	Riser	FLCRZ04Y	FLCRZ06Y	FLCRZ12Y	FLNRZ24Y	FLNRZ48Y
<b>Singlemode</b>	LSZH	FLCL904Y	FLCL906Y	FLCL912Y	FLNL924Y	FLNL948Y
	Riser	FLCR904Y	FLCR906Y	FLCR912Y	FLNR924Y	FLNR948Y

### Opticore All-Dielectric Outside Plant Cable, Gel-Filled

- Gel-filled water blocked loose tubes and UV resistant outer jacket
- For use in aerial (with messenger wire) and duct applications
- Non-metallic cable does not require grounding and bonding

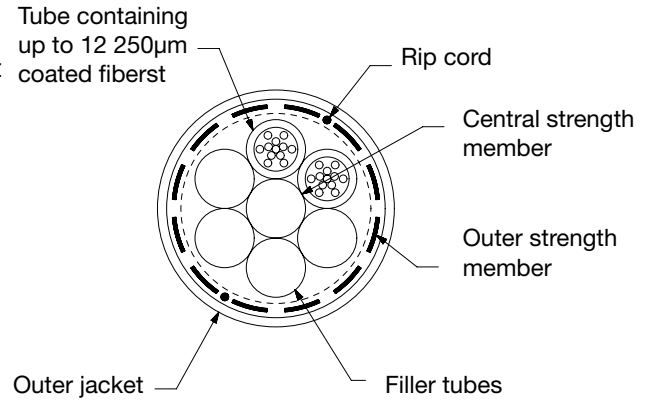

	4-Fiber	6-Fiber	8-Fiber	12-Fiber	24-Fiber
<b>Multimode OM3</b>	–	FLTNX06	–	FLTNX12	FLTNX24
<b>Multimode OM4</b>	–	FLTNZ06	–	FLTNZ12	FLTNZ24
<b>Singlemode</b>	FLTN904	FLTN906	FLTN908	FLTN912	FLTN924

### Opticore Armored Outside Plant Cable, Gel-Filled

- Corrugated steel tape armor provides crush resistance and rodent protection
- Gel-filled water blocked loose tubes and UV resistant outer jacket
- Applications include ducts, trays and direct burial

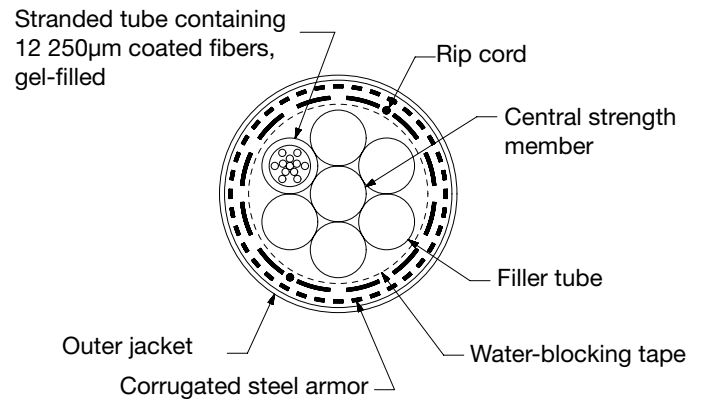
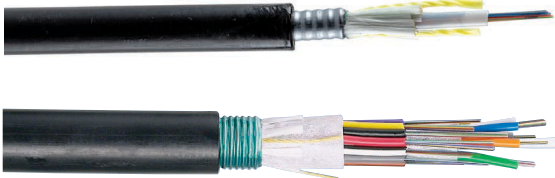

	Central Tube						Stranded Tube			
	2-Fiber	4-Fiber	6-Fiber	8-Fiber	12-Fiber	24-Fiber	48-Fiber	72-Fiber	96-Fiber	144-Fiber
<b>Multimode OM3</b>	–	–	FLSNX06	–	FLSNX12	FLSNX24	–	–	–	–
<b>Multimode OM4</b>	–	–	FLSNZ06	–	FLSNZ12	FLSNZ24	–	–	–	–
<b>Singlemode</b>	FLSN902	FLSN904	FLSN906	FLSN908	FLSN912	FLSN924	FLWN948	FLWN972	FLWN996	FLWN91A

## Opticore All-Dielectric Outside Plant Cable, Gel-Fille

- Provides a secure bond to the armor sheath on indoor and indoor/outdoor fiber optic cables at both cassette and enclosure ends
- Worm-gear design evenly distributes forces across the armor, is compatible with common armor for long term reliability

Part Number	Description
<b>ACGK</b>	Armored cable grounding kit with one grounding terminal for #6 AWG and one #10 mechanical clamp, 9/16" – 1 1/16" diameter range.
<b>ACG24K</b>	#6 AWG(16mm <sup>2</sup> ) jumper for armored cable diameter up to 0.84" (21.3mm); 24" (609.6mm) length; factory terminated on one end with LCC6 twohole copper compression lug and the other end with grounding terminal; provided with two each #12-24 and M6 thread-forming screws and a Black polypropylene terminal cover
<b>ACG24K-500</b>	#6 AWG(16mm <sup>2</sup> ) jumper for armored cable diameter 0.85" (21.3mm) to 1.03" (26.2mm); 24" (609.6mm) length; factory terminated on one end with LCC6 two-hole copper compression lug and the other end with grounding terminal; provided with two each #12-24 and M6 thread-forming screws and a Black polypropylene terminal cover.
<b>ACG24KX-500</b>	#6 AWG(16mm <sup>2</sup> ) jumper for armored cable diameter 0.94" (23.9mm) to 1.5" (38.1mm); 24" (609.6mm) length; factory terminated on one end with LCC6 two-hole copper compression lug and the other end with grounding terminal; provided with two each #12-24 and M6 thread-forming screws and a Black polypropylene terminal cover.



## Cable Slack Spool

- Can be mounted to 4 post racks or used in vertical building risers

Part Number	Description
<b>WMFS24</b>	Wall Mount Fiber Spool 24" – provides proper bend radius for excess cable storage. The steel ring has many different mounting options, including wall mount or various mounting methods to 4 post racks. The ring is 24 inches in diameter. Includes hook and loop for easy cable tie-off. Product is Black.

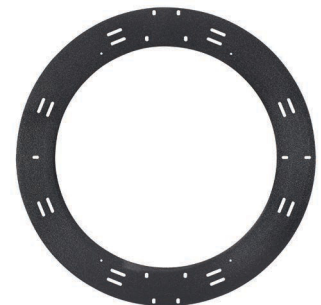

### OptiCam® Pre-Polished Cam Fiber Optic Termination Kit

- For termination of all Panduit OptiCam Pre-Polished Connectors
- OptiCam 2 Termination Tool simplifies tooling and termination by providing calculated insertion loss at the point of termination



### OptiCam® Pre-Polished and Fusion Splice Fiber Optic Connectors

- TIA/EIA-604 FOCIS compatible connectors
- Exceed TIA/EIA-568-D.3 requirements
- Connector housing and boot colors follow TIA/EIA-568-D.3 suggested color identification scheme
- Non-optical disconnect on OptiCam Connectors maintain data transmission under tensile loads for jacketed cable
- Quick installation provides field termination in less than half the time of field polish connectors
- Patented re-termination capability on OptiCam Connectors provide yield rates approaching 100%
- Factory pre-polished fiber endface eliminates time-consuming field polishing to reduce installation costs, labor, scrap and the number of tools required
- OptiCam Cam activated fiber and buffer clamp mechanisms provide superior fiber and buffer retention – less sensitivity to fiber tensile loading

# Pre-Polished Fiber Optic Kit & Connectors

## OptiCam® Pre-Polished Fiber Optic Connectors

### LC OptiCam® Pre-Polished Fiber Optic Connectors

- Quick installation – provides field termination in less than half the time of field polish connectors. Patented re-termination capability.

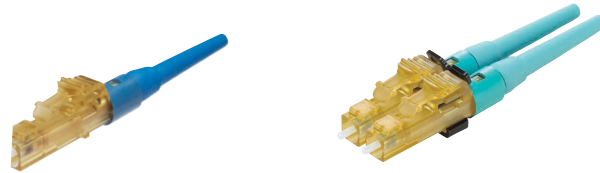

#### selection information

Part Number	Connector Type	Ferrule Material	Fiber	Ferrule Finish	Backbone Color	Boot Color	Average Insertion Loss**	Return Loss
FLCSMCXAQY	Simplex	Zirconia Ceramic	10 GbE 50/125µm (laser optimized) OM3/OM4	PC	Aqua	Aqua	0.3dB	>26dB
FLCDMCXAQY	Duplex							
FLCSMC6EIY	Simplex	Zirconia Ceramic	62.5/125µm OM1	PC	Electric Ivory	Electric Ivory	0.3dB	>20dB
FLCSSCBUY	Simplex	Zirconia Ceramic	9/125µm OS1/OS2	UPC	Blue	Blue	0.3dB	>50dB
FLCDSCBUY	Duplex							

\*\*All connector insertion loss values calculated from tests taken with precision launch jumper assemblies per TIA/EIA-FOTP-171.

Add-C for 100 pack connectors.

Simplex connectors can be made into duplex using FLCCLIPBL-L.

### SC OptiCam® Pre-Polished Fiber Optic Connectors



#### selection information

Part Number	Connector Type	Ferrule Material	Fiber	Ferrule Finish	Housing Color	Backbone Color	Boot Color	Average Insertion Loss**	Return Loss
FSC2MCXAQ	Simplex	Zirconia Ceramic	10 GbE 50/125µm (laser optimized) OM3/OM4	PC	Black	Aqua	Aqua	0.3dB	>26dB
FSC2DMCXAQ	Duplex								
FSC2MC6EI	Simplex	Zirconia Ceramic	62.5/125µm OM1	PC	Electric Ivory	Electric Ivory	Electric Ivory	0.3dB	>20dB
FSC2DMC6EI	Duplex	Zirconia Ceramic	62.5/125µm OM1	PC	Electric Ivory	Electric Ivory	Electric Ivory	0.3dB	>20dB
FSC2SCBU	Simplex	Zirconia Ceramic	9/125µm OS1/OS2	UPC	Blue	Blue	Blue	0.3dB	>50dB

\*\*All connector insertion loss values calculated from tests taken with precision launch jumper assemblies per TIA/EIA-FOTP-171.

Add-C for 100 pack connectors.

Simplex connectors can be made into duplex using FSCCLIP-L.

## ST OptiCam® Pre-Polished Fiber Optic Connectors



Part Number	Connector Type	Ferrule Material	Fiber	Ferrule Finish	Backbone Color	Boot Color	Average Insertion Loss**	Return Loss
<b>FST2MCXAQ</b>	Simplex	Zirconia Ceramic	10 GbE 50/125µm (laser optimized) OM3/OM4	PC	Natural	Aqua	0.3dB	>26dB
<b>FST2MC6EI</b>	Simplex	Zirconia Ceramic	62.5/125µm OM1		Natural	Electric Ivory	0.3dB	>20dB
<b>FST2SCBU</b>	Simplex	Zirconia Ceramic	9/125µm OS1/OS2	UPC	Natural	Blue	0.3dB	>50dB

\*\*All connector insertion loss values calculated from tests taken with precision launch jumper assemblies per TIA/EIA-FOTP-171.

## Fusion Splice Fiber Optic Connectors



Part Number	Connector Type	Polish	Color	Fiber	Insertion Loss*	Return Loss
<b>FLCS2/9SOCU9BU</b>	Simplex LC	UPC	Blue	9/125µm OS1/OS2	0.15dB Average	>55dB
<b>FLCS2/9SOCA9AG</b>	Simplex LC	APC	Green	9/125µm OS1/OS2	0.15dB Average	>65dB
<b>FLCS2/9SOCPXAQ</b>	Simplex LC	PC	Aqua	50/125µm OM2, OM3, OM4	0.10dB Average	>30dB
<b>FSCS2/9SOCU9BU</b>	Simplex SC	UPC	Blue	9/125µm OS1/OS2	0.15dB Average	>55dB
<b>FSCS2/9SOCA9AG</b>	Simplex SC	APC	Green	9/125µm OS1/OS2	0.15dB Average	>65dB
<b>FSCS2/9SOCPXAQ</b>	Simplex SC	PC	Aqua	50/125µm OM2, OM3, OM4	0.10dB Average	>30dB

## Fiber Optic Termination Accessories



Part Number	Description
<b>FSPCVR</b>	Precision fiber optic cleave tool with rotary blade for 7mm and 10mm cleaves.connector termination.
<b>FO6CB</b>	The fan-out kit for six fibers is used to build up 250µm fiber to the 900µm tight-buffered coating size for connector termination. LC
<b>FO12CB</b>	The fan-out kit for twelve fibers is used to build up 250µm fiber to 900µm tight-buffered coating size for connector termination.
<b>F250BT-C</b>	250 micron fiber build-up tube kit, includes 100 build-up tubes and supplemental installation instructions to build up to 250µm fiber to 900µm.
<b>FOLPC-1.25MM</b>	1.25mm Multimode fiber optic patch cord for OCTT2 (termination tool).
<b>FOLPC-1.25SM</b>	1.25mm Singlemode fiber optic patch cord for OCTT2 (termination tool).
<b>FOLPC-2.5MM</b>	2.5mm Multimode fiber optic patch cord for use with OCTT2 (termination tool).
<b>FOLPC-2.5SM</b>	2.5mm Singlemode fiber optic patch cord for use with OCTT2 (termination tool).
<b>OCTTR1.25SS</b>	Replacement 1.25mm split sleeves for Opticam Termination Tool. 5 sleeves.
<b>OCTTR2.5SS</b>	Replacement 2.5mm split sleeves for Opticam Termination Tool. 5 sleeves.
<b>FLCCLIPBL-L</b>	LC Duplex Clip, Pack of 50, for OptiCam Connectors, Black.



**PANDUIT®**

**Panduit Corp.  
World Headquarters  
Tinley Park, IL 60487**

**cs@panduit.com**

**US and Canada: 800.777.3300**

**Europe, Middle East, and Africa:**

**44.20.8601.7200**

**Latin America: 52.33.3777.6000**

**Asia Pacific: 65.6305.7575**

**[www.panduit.com](http://www.panduit.com)**